



DSP282A Dual Intel 5th Gen Quad Core i7 6U OpenVPX Deployed Server Platform

The Abaco Systems DSP282A is a rugged 5th generation, COTS multiprocessor that brings data center performance and scalability to deployed defense and aerospace applications.

Designed for size, weight and power (SWaP) sensitive applications, Abaco's high performance embedded computing (HPEC) platforms deliver expanded mission capabilities across a wide range of manned- and un-manned airborne, ground and naval platforms.

More GigaFLOPS , same SWaP

The DSP282A delivers up to 665.6 GFLOPS per card slot, and increased system bandwidth with two Intel® 5th gen quad Core™ i7 CPUs, up to 16 GBytes DDR3L main memory per processor, inter-node communication over PCIe™ gen 3 and OFED RDMA or Ethernet data plane via the latest Mellanox ConnectX™ -3 network interface controller (rNICs).

Planned technology insertion

Abaco launched the DSP28X platform architecture in 2011 with the DSP280 COTS Processor. Developers can leverage proven software support for this open architecture now with a clear path to the new DSP282/DSP282A Intel 'Broadwell' platform to capture the latest micro-architecture/performance boost.

Open System Architecture (OSA)

Abaco Systems provides a rugged, scalable solution that builds on open standards from the wider high performance computing (HPC) and 'Big Data' communities to exploit widely used application programming interfaces (APIs), high performance middleware, libraries and productivity tools that greatly reduce cost of ownership, technical risk and time-to-deployment .

Sensor-, image- and data processing

Abaco goes further to fully exploit Intel's hyper-threaded multi-core platform with AXIS Advanced Multiprocessor Integrated Software. Developers can optimize and scale applications across Abaco's 3U and 6U OpenVPX HPEC solution sets that include Ethernet, GPGPU processors, SBCs and I/O modules.

Typical applications

- Back-end sensor- and image processing
- Radar, sonar, Multi-INT
- Display and mission computing
- Data and network gateways
- HPC clusters
- Distributed Ethernet clusters

FEATURES:

- Two Intel® Core™ i7-5700EQ CPUs
 - Four cores, eight threads per CPU
 - Two channels ECC 1600-DDR3L
 - 16 GBytes DDR3L
 - AVX2.0 Advanced Vector Extensions
 - HD-5600 on-chip graphics
- Two platform controller hubs
 - 16 MBytes BIOS Flash per PCH
 - 16 GBytes SATA NAND Flash
 - 256 Kbytes NRAM
- Fabric
 - 10/40GigE
- Platform security
 - Optional security hub FPGA
 - Intel Trusted Execution
 - Intel ES new instructions
- Firmware support
 - Built-in Test
 - UEFI BIOS
- Operating system support
 - Linux® SDK
 - Windows® SDK
 - WRS VxWorks® BSP
- Middleware and Libraries
 - AXISPro application dev. framework with AXISFlow and AXISmpi communication libraries
 - AXISLib VSIPL and RSPL multi-threaded DSP and math libraries for VxWorks, Linux and Windows
 - Abaco signal and image processing quick start examples
 - Intel OpenCL SDKs, IPP and MKL

DSP282A Dual Intel 5th Gen Quad Core i7 6U OpenVPX Deployed Server Platform

Specifications

6U OpenVPX VITA65

- SLT6-PAY-4F1Q2U2T-10.2.6
- MOD6-PAY-4F1Q2U2T-12.2.1-8/15

Build Options

- VITA48.1-1" pitch convection cooled
- VITA48.2-1" pitch conduction cooled
- VITA48.5-1.2" pitch air flow through Wide temperature, extended shock and vibration builds – consult factory

Intel 5th Gen Core processor

- Quad core i7-5700EQ (eight threads)
- 2.6 GHz base frequency

Memory per CPU node

- 6 MBytes on-chip last level cache
- 16 GBytes DDR3L 1600 with ECC per CPU
- 16 MBytes BIOS, BIT and back-up Flash
- 16 GBytes SATA NAND Flash disk
- 512 Kbytes NVRAM

OpenVPX I/O planes Management:

- I2C with BMM

Data:

- 4 x Fat Pipes – Ethernet via 2 x dual port Mellanox ConnectX-3 10/40GE RDMA NICs

Expansion:

- 2 x Double Fat Pipes or 4 x Fat Pipes – PCIe via PLX Tech gen 3 switch with inter-node DMA via NT port

Control:

- 2 x 1000Base-T and 2 x 1000Base SERDES with IEEE-1588 PTP (precision time protocol) support

User I/O:

- 2 x 1000Base-T vPRO ports, Serial, 4 x USB-2, 2 x USB-3, 4 x SATA-3, GPIO, HD audio

Display:

- 2 x HDMI/DVI

Block diagram

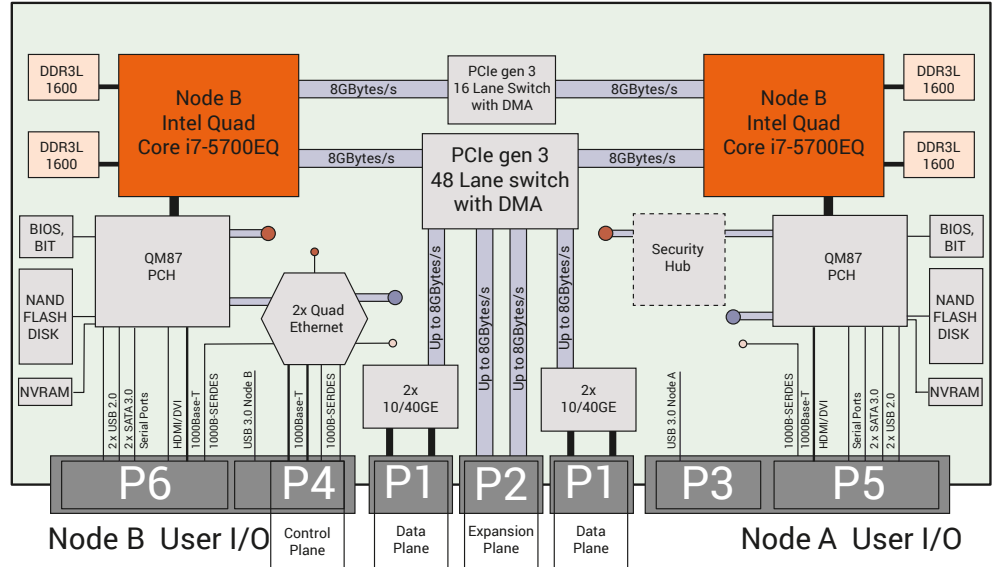

The AXISPro-01M development environment supports application optimization on multi-core, multi-threaded and multi-node distributed system architectures across multiple operating systems including Linux, Windows and VxWorks and includes quick start signal and image processing examples to accelerate time-to-solution.



AXIS RuntimeView screen shot – multi-threaded application on dual Intel Core-7 processor.

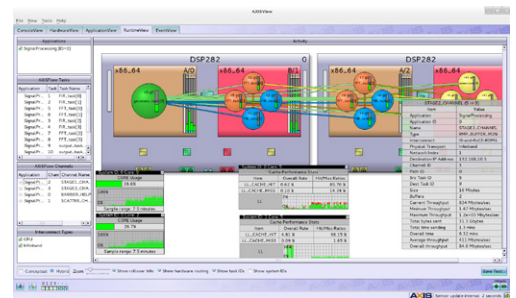

AXIS Quick Start application.

Ordering information

Contact Abaco Systems for pricing and availability.

WE INNOVATE. WE DELIVER. YOU SUCCEED.

Americas: 866-OK-ABACO or +1-866-652-2226 Asia & Oceania: +81-3-5544-3973

Europe, Africa, & Middle East: +44 (0) 1327-359444

Locate an Abaco Systems Sales Representative visit: abaco.com/products/sales

abaco.com | @AbacoSys

©2017 Abaco Systems. All Rights Reserved. All other brands, names or trademarks are property of their respective owners. Specifications are subject to change without notice.

